

Racing Bantam Timing Side Crank Half.

Crank Material EN24T.
Surface harden after machining to 45 Rockwell
to depth of 20 thou max. Check sizes and regrind
where needed.

Reduce crankpin Length evenly both sides
To 50.30 mm

Crankpin Hole 0.5 thou to 0.75 thou interference
on crankpin. Fine Ground finish the hole on the
27.25 mm centre Parallel to mainshaft.

Side float on conrod 2.0 mm total

Use Rd400 Conrod assembly with this crank.

Stroke 54.50mm

PVL IGNITION ARRANGEMENT.

Do Not SCALE

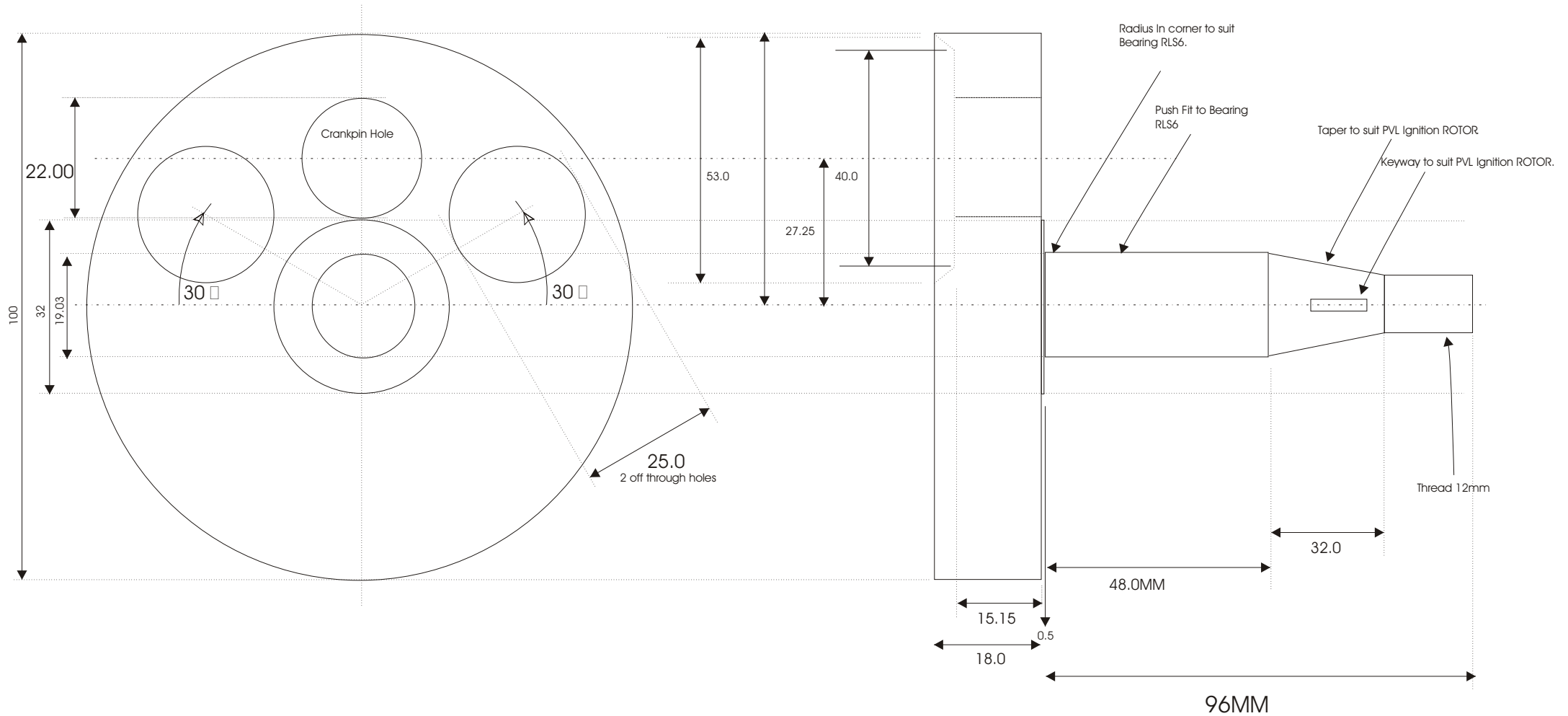

Hidden Detail Of Balance holes missed Off
For Clarity On This side of the drawing.